

## Two winning options for air conveyor.

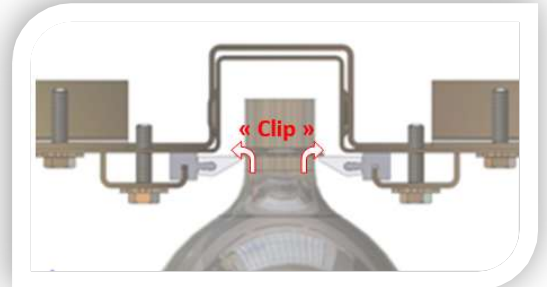

### Quick change under neck guide

### **Efficiency and Adaptability**

- Suitable on almost all air conveyors.
- Lowering Coefficient of friction (0,06).
- Energy saving - lowering energy cost.
- Aeraulic Management more dynamic.
- Suitable for contact with foodstuffs-FDA/EU.
- PCO- 1881 short neck.
- Efficiency increased.
- fix adjustment.

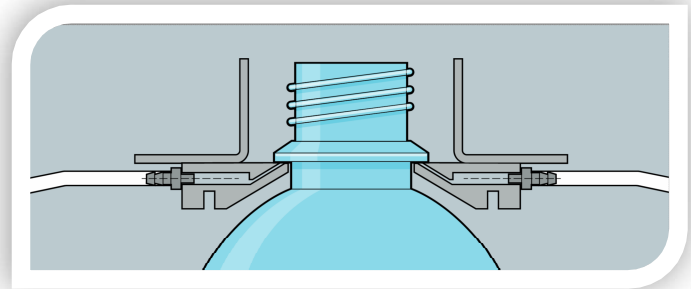

### Dry-Lub coating

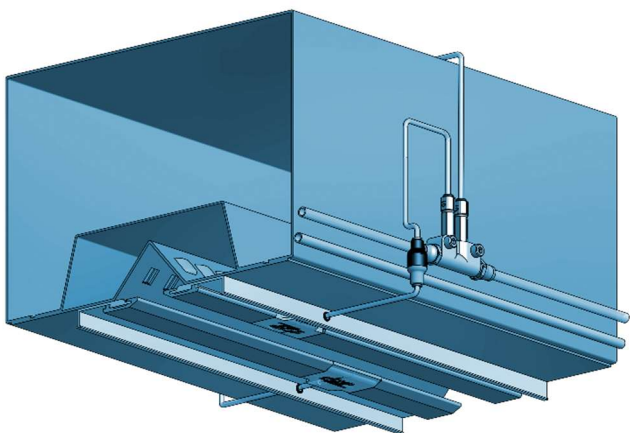

**Increase air  
conveyor efficiency.**

**+ 0,5% à 2,5%**

**70% - 100%  
blockages less**